

# FLUID COOLING | Mobile DH Series

AIR COOLED DH

## Features

- Excellent for Radiator Face Mount Cooling
- 3/4" Tube Size
- Steel or Aluminum Fin
- Copper Manifolds – One Row
- Steel Manifolds – Two Row
- High Performance Oil Turbulators
- Rugged Off-Highway Steel Designs Available
- Oil Flows to 150 GPM, Heat Removal to 175,000 BTU/HR
- Oil Cooler
- Transmission Cooler
- Fuel Cooler

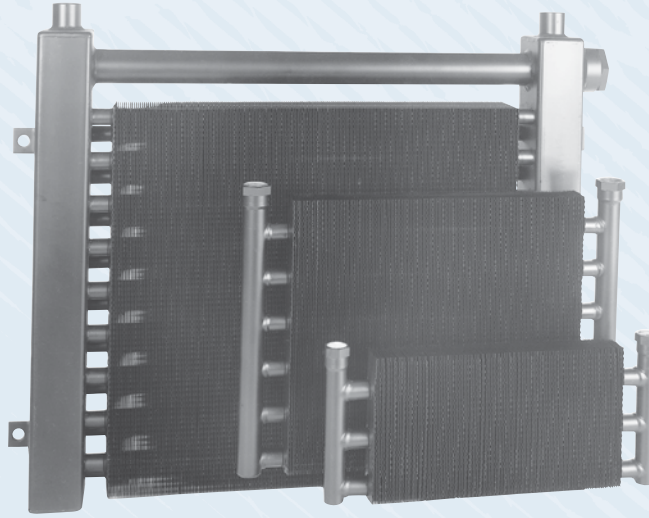

## OPTIONS

- Built-in Relief Bypass
- Steel Components
- Custom Sizes/ Mounting Brackets
- Connection Sizes/ Locations
- Corrosion Resistant Marine Coating

## Ratings

- Operating Pressure** 300 psi
- Test Pressure** 300 psi
- Operating Temperature** 350° F

## Materials

- Tubes** Copper
- Fins** Aluminum or Steel
- Turbulators** Aluminum
- Manifolds** Copper: Models DH-051 – DH-447  
Steel: Models DH-513 – DH-670
- Connections** Brass: Models DH-051 – DH-447  
Steel: Models DH-513 – DH-670

## Relief Bypass Valve Option

MODEL	DESCRIPTION
DH-051 thru DH-447	Available in either 30 psi or 60 psi settings. Bypass valve is built into tubes and does not effect external dimensions. All steel valves. Not serviceable.
DH-513	Available in either 30 psi or 60 psi settings. 3/4", external all steel valve. May be removed for servicing.
DH-524 thru DH-670	Available in either 30 psi or 60 psi settings. 1-1/2", external, all steel valve. May be removed for servicing.

## How to Order

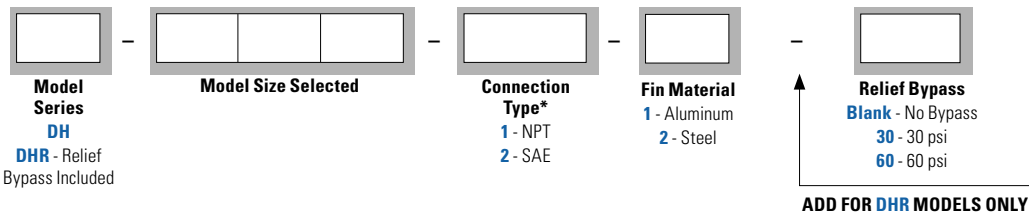

Examples: DH-051-1-1 or DHR-062-2-2-30

**Note: All positions must be filled. Mounting Kits (where needed) must be ordered separately, by part number.**

\*Other connection types available. Please consult factory for assistance.

# Dimensions & Weights

## DH-051 thru DH-447

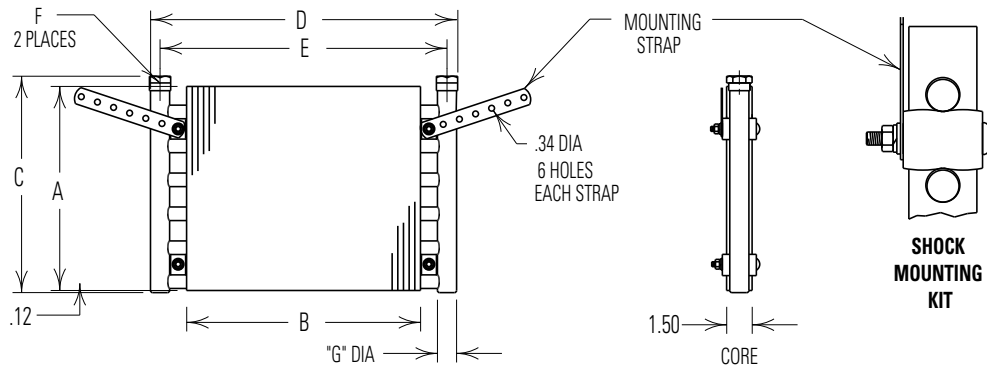

### Mounting Kits

Optional Mounting Kits are available with or without straps.

	Part Number
With strap	L-84741
Without strap	L-84740

MODEL	A	B	C	D	E	F		G DIA	QTY MTG KITS	FACE AREA SQ FT	WEIGHT LBS.			
						NPT	SAE							
DH-051	4.00	11.25	4.50	15.00	14.12	0.50	#10	0.88	2	0.31	2			
DH-062				15.00	14.12					0.47	3			
DH-073	6.00	14.25	6.50	18.00	17.12				4	0.60	3			
DH-084		20.25		24.00	23.12					0.84	4			
DH-095		14.25	8.50	18.00	17.12					0.79	4			
DH-106	8.00	17.25		21.00	20.12					0.96	5			
DH-117		20.25		24.00	23.12					1.12	5			
DH-194		13.75	12.73	18.00	16.88					0.75	#12	1.12	1.15	6
DH-205	12.00	16.75		21.00	19.88								1.40	7
DH-216				24.00	22.88								1.64	8
DH-227	14.00	19.75		14.73	24.00	22.88	1.92	9						
DH-249	18.00		18.73	24.00	22.88	2.47	12							
DH-326	24.00	19.25	25.00	24.00	22.62	1.00	#16	1.38	3.21				16	
DH-337		25.25		30.00	28.62				4.21	20				
DH-348		19.25	31.00	24.00	22.62				4.00	19				
DH-359	30.00	25.25		30.00	28.62				5.26	24				
DH-370		31.25		36.00	34.62				6.51	28				
DH-425	36.00	24.75	37.41	30.00	28.38				1.25	#20	1.62	6.19	32	
DH-447	40.00	36.75	41.41	42.00	40.38							10.21	43	

All dimensions in inches. Weights are for aluminum fins.

After making your base model selection with the connection of your choice, please refer to the How to Order section.

Note: We reserve the right to make reasonable design changes without notice.

# Dimensions & Weights

## DH-513 thru DH-670

AIR COOLED DH

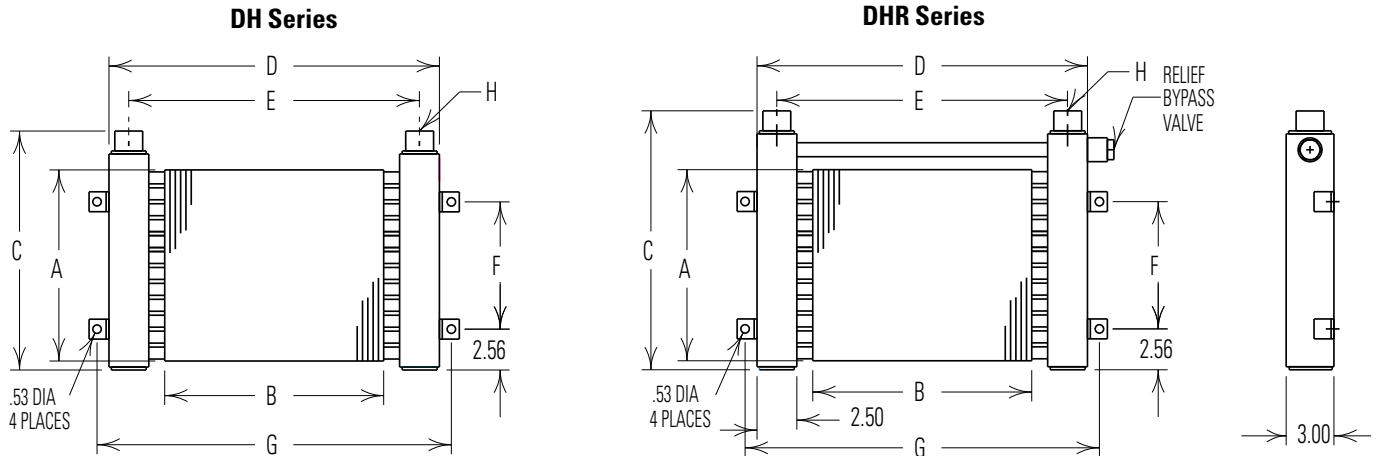

MODEL	A	B	C		D		E	F	G	H		FACE AREA SQ. FT.	WEIGHT LBS.
			DH	DHR	DH	DHR				NPT	SAE		
DH-513	12.00	13.75	15.00	16.25	20.75	22.41	18.25	8.00	22.25	0.75	#12	1.15	16
DH-524	18.00	19.75	21.00	23.25	26.75	28.13	24.25	14.00	28.25			2.47	27
DH-535	24.00	19.25	27.00	29.25	26.75	27.63	23.75	20.00	27.75	1.00	#16	3.21	53
DH-626	36.00	22.75	39.03	41.20	29.75	31.13	27.25	32.00	31.25	2.00	#32	5.69	60
DH-670	40.00	34.75	43.03	45.28	41.75	43.13	39.25	36.00	43.25			9.65	115

All dimensions in inches. Weights are for aluminum fins.  
After making your base model selection with the connection of your choice, please refer to the How to Order section.

### Desired Reservoir Temperature

**Return Line Cooling:** Desired temperature is the oil temperature leaving the cooler. This will be the same temperature that will be found in the reservoir.

**Off-Line Recirculation Cooling Loop:** Desired temperature is the oil temperature entering the cooler. In this case, the oil temperature change must be determined so that the actual oil leaving temperature can be found. Calculate the oil temperature change (oil  $\Delta T$ ) with this formula:  
Oil  $\Delta T = (\text{BTU's/Hr.}) / (\text{GPM Oil Flow} \times 210)$ .

To calculate the oil leaving temperature from the cooler, use this formula:  
Oil Leaving Temp. = Oil Entering Temp – Oil  $\Delta T$ .

This formula may also be used in any application where the only temperature available is the entering oil temperature.

**Oil Pressure Drop:** Most systems can tolerate a pressure drop through the heat exchanger of 20 to 30 PSI. Excessive pressure drop should be avoided. Care should be taken to limit pressure drop to 5 PSI or less for case drain applications where high back pressure may damage the pump shaft seals.

### Oil Temperature

Typical operating temperature ranges are:

Hydraulic Motor Oil	110° - 130°F
Hydrostatic Drive Oil	130° - 180°F
Bearing Lube Oil	120° - 160°F
Lube Oil Circuits	110° - 130°F

Oil Temp °F	TYPICAL OIL VISCOSITY, SSU				
	SAE 5	SAE 10	SAE 20	SAE 30	SAE 40
100	110	150	275	500	750
150	60	70	100	135	190
210	40	43	50	65	75

# Performance Curves

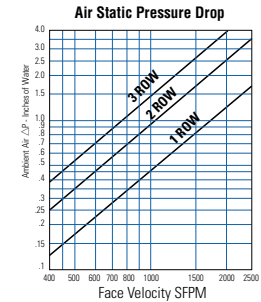
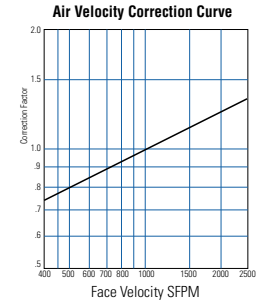
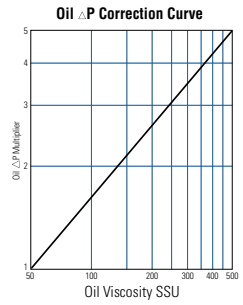
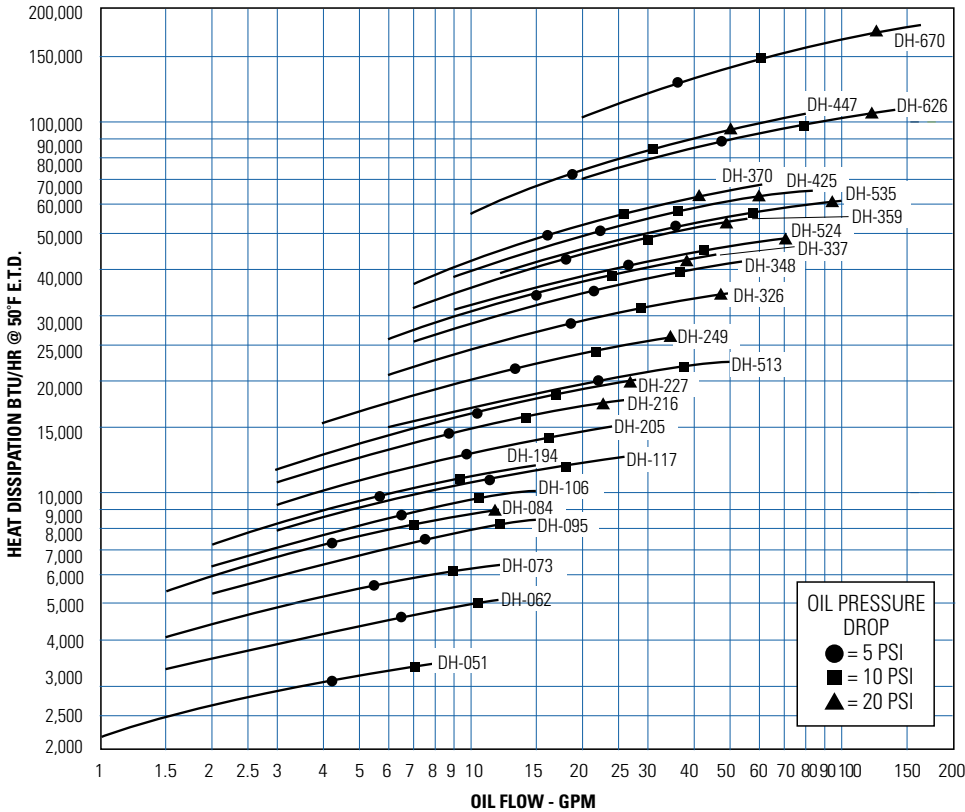

## Selection Procedure

Performance Curves are based on 50 SSU oil, 1000 Standard Feet per Minute (SFPM) Air Velocity, and a 50°F Entering Temperature Difference (E.T.D.)  
E.T.D. = Entering oil temperature - Ambient air temperature

**Step 1 Determine Heat Load:** Heat load may be expressed as either Horsepower or BTU/Hr. BTU/Hr. = Horsepower x 2545

**Step 2 Determine entering temperature difference:** The entering oil temperature is generally the maximum desired system temperature. E.T.D. = Entering oil temperature - Ambient air temperature.

**Step 3 Determine the corrected heat dissipation to use the curves:**

$$\text{Corrected Heat Dissipation} = \frac{\text{BTU/HR. (Heat Load)}}{\text{(Heat Load)}} \times \left[ \frac{50^\circ\text{F} \times C_v}{\text{Desired E.T.D.}} \times \frac{\text{Air Velocity}}{\text{Correction Factor}} \right]$$

**Step 4 Enter the Performance Curves** at the bottom with the GPM oil flow and proceed upward to the adjusted heat load from Step 3. Any curve on or above this point will meet these conditions.

**Step 5 Calculate actual SFPM Air Velocity or SCFM** (Standard Cubic Feet Per Minute) using the Face Area from the table.

$$A. \text{ SFPM Air Velocity}^* = \frac{\text{SCFM Air Flow}}{\text{Square Feet Face Area}}$$

$$B. \text{ SCFM Air Flow} = \text{SFPM Air Velocity} \times \text{Square Feet Face Area}$$

\*If the Air Velocity calculated is different than the value in Step 3, recheck Corrected oil Pressure Drop.

**Step 6 Multiply Oil Pressure Drop** from curve by correction factor found in Oil Δ P Correction Curve.

\*Note: If air velocity is unknown assume 750 SFPM.

## C<sub>v</sub> Viscosity Correction

Average Oil Temp °F	OIL				
	SAE 5 110 SSU at 100°F 40 SSU at 210°F	SAE 10 150 SSU at 100°F 43 SSU at 210°F	SAE 20 275 SSU at 100°F 50 SSU at 210°F	SAE 30 500 SSU at 100°F 65 SSU at 210°F	SAE 40 750 SSU at 100°F 75 SSU at 210°F
100	1.14	1.22	1.35	1.58	1.77
150	1.01	1.05	1.11	1.21	1.31
200	.99	1.00	1.01	1.08	1.10
250	.95	.98	.99	1.00	1.00